

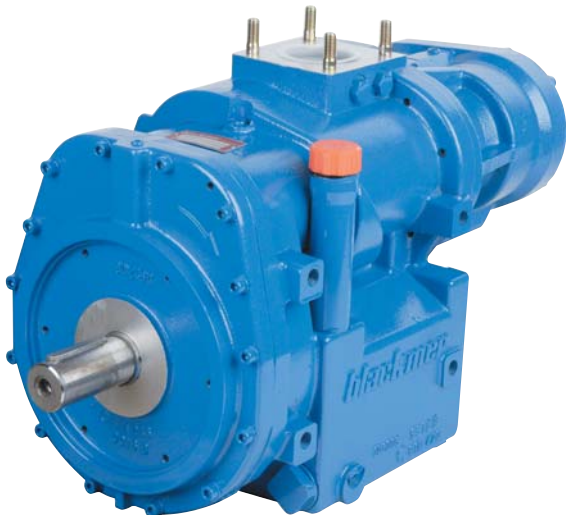

Screw compressor MISTRAL

The specialist
- 365 up to 750 m³/hr -



MISTRAL-20R

1200 - 2000 rpm CW



MISTRAL-30R

1800 - 3000 rpm CW



Dimensions (mm) :

L 587 x H 355 x W 280

Weight :

102 kg

The solution for a conform mounting
on European trucks.

MISTRAL-13R/15L

either 780 - 1300 rpm CW
or 900 - 1500 rpm CCW



MISTRAL-19R/22L

either 1170 - 1950 rpm CW
or 1320 - 2250 rpm CCW



Dimensions (mm) :

L 723 x H 442 x W 295

Weight :

132 kg





Screw compressor MISTRAL

The specialist - 365 up to 750 m³/h -

Speed (rpm)

COMPRESSOR SPEED

VERSION	1	2	3	4	5
13R	780	910	1040	1170	1300
15L	900	1050	1200	1350	1500
19R	1170	1365	1560	1755	1950
20R	1200	1400	1600	1800	2000
22L	1320	1580	1800	2035	2250
30R	1800	2100	2400	2700	3000

Flow (m³/hr) / Power (kW)

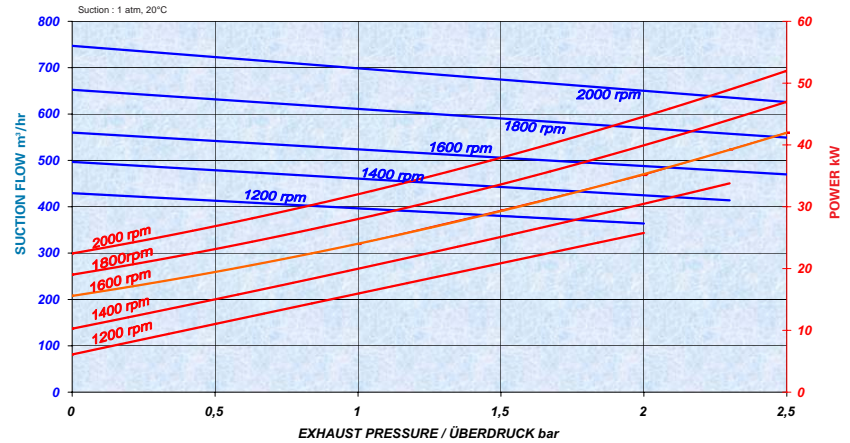

Torque Pressure (Nm)

VERSION	1.5	2.0	2.5
13R	280	330	360
15L	370	440	480
19R	189	221	263
20R	180	210	250
22L	164	191	227
30R	120	140	165

*At full speed

MISTRAL COMPRESSOR 20R and 30R

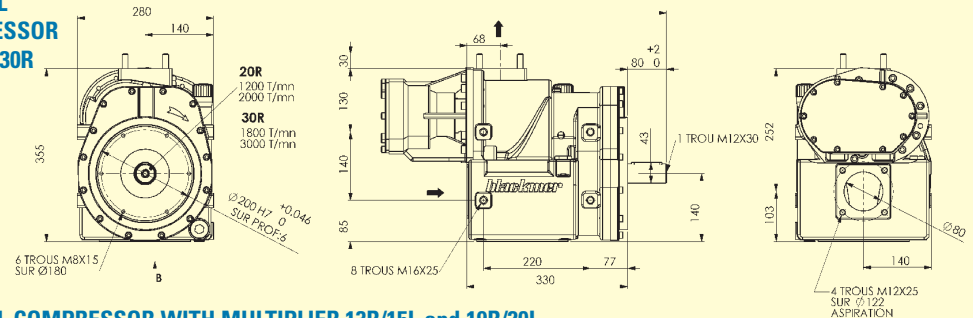

MISTRAL COMPRESSOR WITH MULTIPLIER 13R/15L and 19R/20L

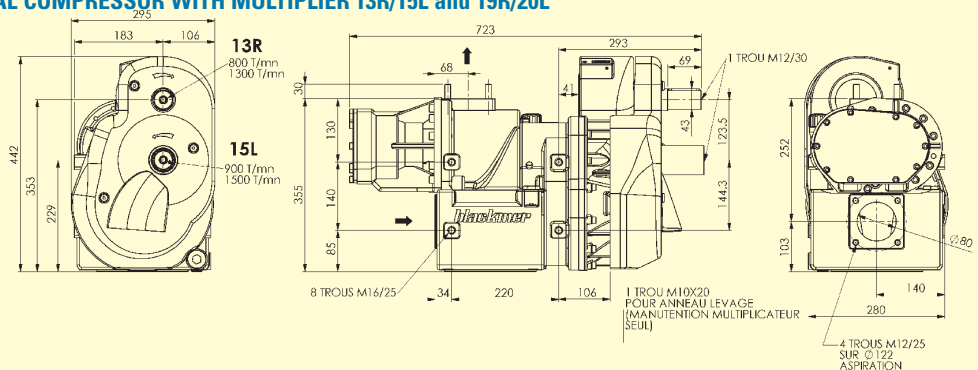

World Headquarters

1809 Century Avenue SW • Grand Rapids, MI 49503-1530 USA • T 616.241.1611 F 616.241.3752

European Headquarters

ZI la Plaine des Isles, rue des Caillottes 89000 Auxerre, FRANCE • T +33.3.86.49.86.30 F +33.3.86.46.42.10
contact@blackmer-movex.com



Distributed by :



Blackmer se reserva el derecho de modificar sin aviso previo las informaciones y presentaciones contenidas en este documento. Documento no contractual.
Printed in FRANCE by Filigrane

© 2005 Blackmer